



# PREFILL AND EXHAUST VALVE PV 100 TO PV 200

ENGINEERING

1

Ref. No. P04906

Release 08/2006

## Description

Seat type construction.

Allows free flow from it's port A to port B.

Flow from port B to port A can be had by applying pilot pressure to it's port X.

The decompression feature enables the valve to open in two stages progressively, allowing smooth and rapid exhaust of the compressed oil.

Opening and closing time of the valve can be influenced by providing Throttle - Check Valves in the X port line.

Flanged port A of the valve housing can be rotated around vertical axis through 360°.



## Section

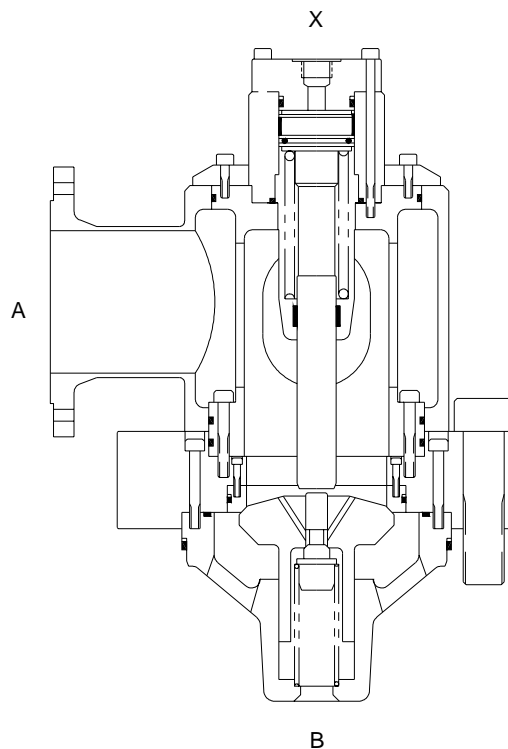

Hydraulic symbol

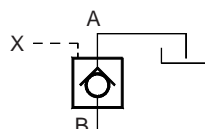

**Polyhydron Pvt. Ltd.**

78-80, Machhe Industrial Estate,  
Machhe, Belgaum - 590 014. INDIA.

**Phone** : +91-(0)831-2411001

**Fax** : +91-(0)831-2411002

**E-mail** : polyhydron@vsnl.com

**Website**: www.polyhydron.com



# PREFILL AND EXHAUST VALVE PV 100 TO PV 200

ENGINEERING

2

Ref. No. P04906

## Unit dimension

Dimensions in mm.

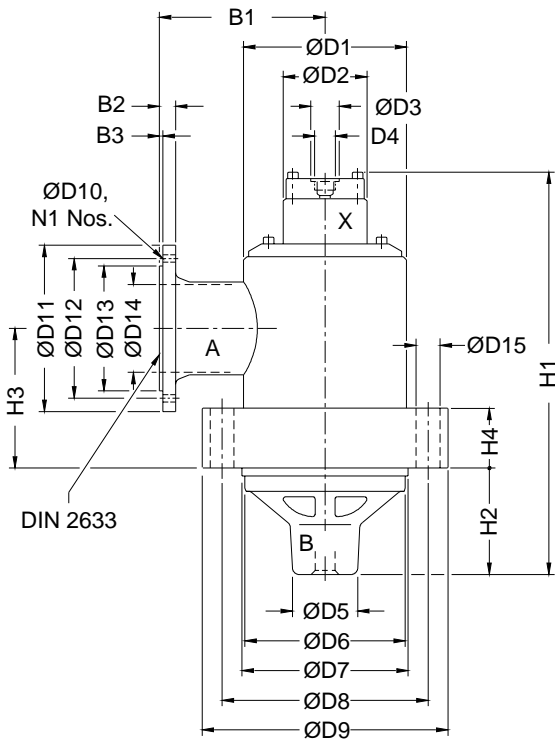
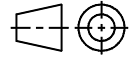

Model 'A'  
With flange connection

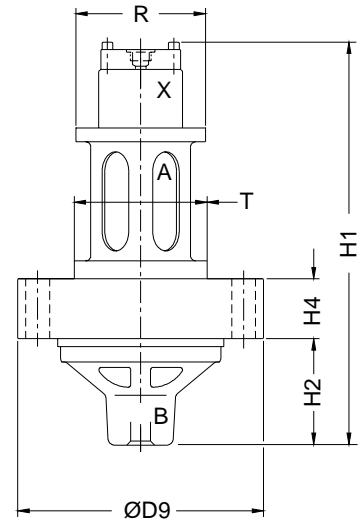
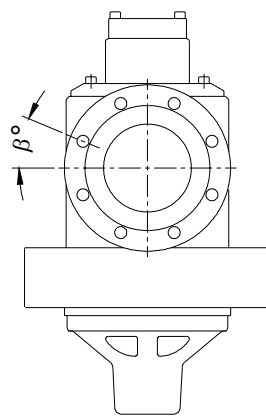

Model 'B'  
Tank Mounting

Size	Mass Kg.	B1	B2	B3	ØD1	ØD2	ØD3	D4	ØD5	ØD6	ØD7	ØD8	R	T
100	79	217	20	3	195	105	36	G3/4	80	191.5	200	250	156	159
125	120	247	22	3	245	135	36	G3/4	105	241.5	250	310	195	200
150	167.5	260	22	3	273	142	44	G1	110	281.5	290	350	230	235
200	310	312	24	3	356	185	54	G1 1/4	135	368.5	380	445	310	315

Size	ØD9	ØD10	ØD11	ØD12	ØD13	ØD14	ØD15	H1	H2	H3	H4	N1	β°
100	295	18	220	180	158	107	33	485	136	171	81	8	22.5
125	370	18	250	210	188	132	40	597	160	210	90	8	22.5
150	407	23	285	240	212	159	40	708	180	250	100	8	22.5
200	510	23	340	295	268	207	45	980	240	352.5	120	12	15



# PREFILL AND EXHAUST VALVE PV 100 TO PV 200

**ENGINEERING**

**3**

Ref. No. P04906

### Mounting cavity details

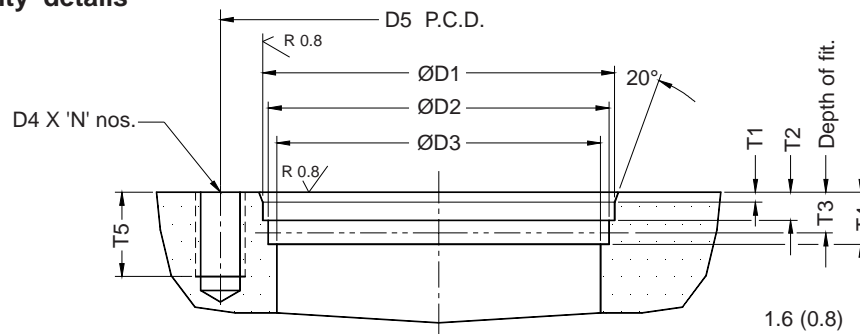

Size	ØD1 <sup>H7</sup>	ØD2 <sup>0.1</sup>	ØD3	D4 x N	D5	T1 <sup>+0.2</sup>	T2	T3	T4	T5	Valve fixing screws	
											S. H. C. Screw size	Tightening Torque
100	200	191.6	180	M30 x 12	250	5	20	34	37	45	M30 x 120 L, 12 nos.	1200 Nm
125	250	241.6	230	M36 x 12	310	5	20	34	37	63	M36 x 150 L, 12 nos.	2250 Nm
150	290	281.6	270	M36 x 15	350	5	20	34	37	55	M36 x 150 L, 15 nos.	2250 Nm
200	380	368.6	355	M42 x 18	445	8	28.5	42	56	60	M42 x 180 L, 18 nos.	4100 Nm

### Technical specification

- Construction ..... Poppet type, Pilot operated.
- Mounting type ..... Inside the oil tank mounting or flanged A port.  
Special machined cavity for port B.
- Mounting position ..... Optional.
- Flow direction ..... Free flow from port A to port B.  
Pilot flow from port B to port A.
- Operating pressure ..... For port A 16 bar, B and X 315 bar.
- Cracking pressure ..... 0.2 bar
- Pilot pressure required to have flow from port B to port A. ....  
 $P_x > [(P_b - P_a) \times 4] + 10$  bar to open main poppet of the valve.  
 $P_x > [(P_b - P_a) \div 10] + 10$  bar to open decompression poppet of the valve.

$P_x$  = Pilot pressure at port X (bar)  
 Where  $P_a$  = Pressure at port A (bar)  
 $P_b$  = Pressure at port B (bar)

Pilot Volume .....

Size	100	125	150	200
cm <sup>3</sup>	46.8	88.5	135.7	313.6

Flow handling capacity .....  
(Nominal) l/min.

Size	At an average velocity of oil through the valve (m/sec)							
	0.5	1	1.5	2	2.5	3	3.5	4
100	235	470	705	940	1175	1410	1635	1880
125	370	740	1110	1480	1850	2220	2590	2960
150	530	1060	1590	2120	2650	3180	3710	4240
200	950	1900	2850	3800	4750	5700	6650	7600

**Note :** Recommended oil velocity during prefilling must be equal to or less than 2 m/sec.

- Oil velocity during pre-filling (suction).... Refer figure below.
- Hydraulic medium ..... Mineral oil
- Viscosity range ..... 10 to 380 cSt.
- Working temperature range ..... -20 °C to +70 °C.
- Fluid cleanliness requirement ..... As per ISO code 16/13 or better.
- Mass ..... Refer individual table



# PREFILL AND EXHAUST VALVE PV 100 TO PV 200

ENGINEERING

4

Ref. No. P04906

Oil velocity during prefilling (suction) for different arrangements :

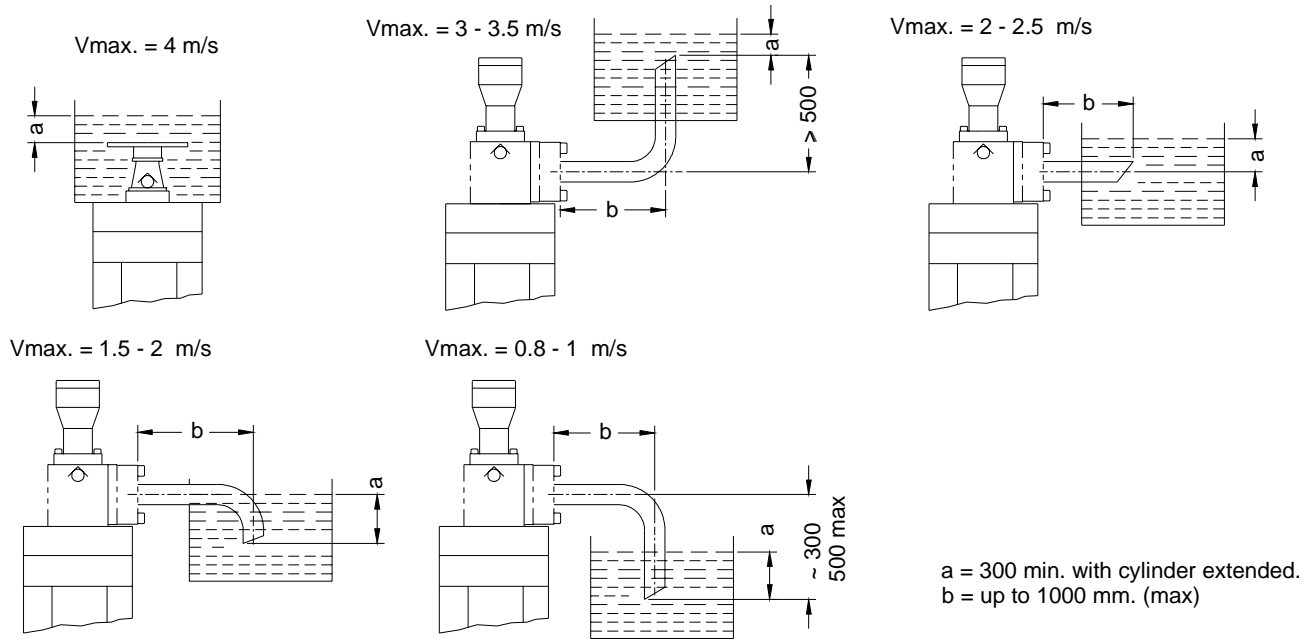

## Ordering code

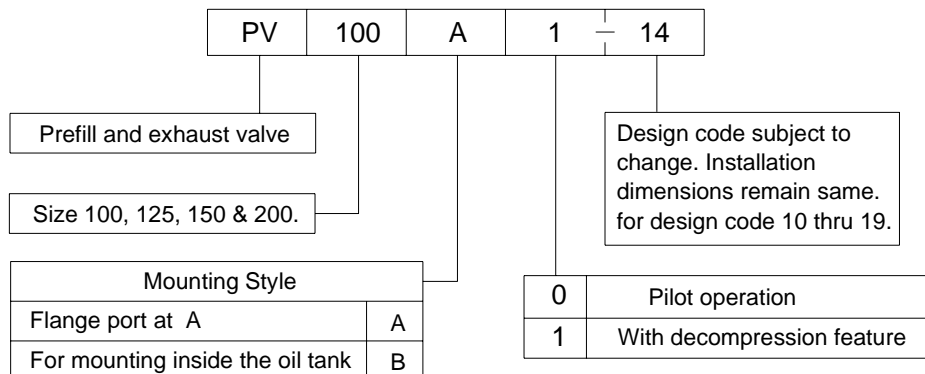



PREFILL AND EXHAUST VALVE  
PV 100 TO PV 200

SERVICE

5

Ref. No. P04906

Sectional View and Parts List

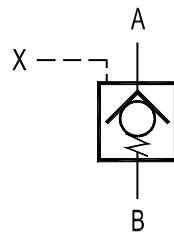
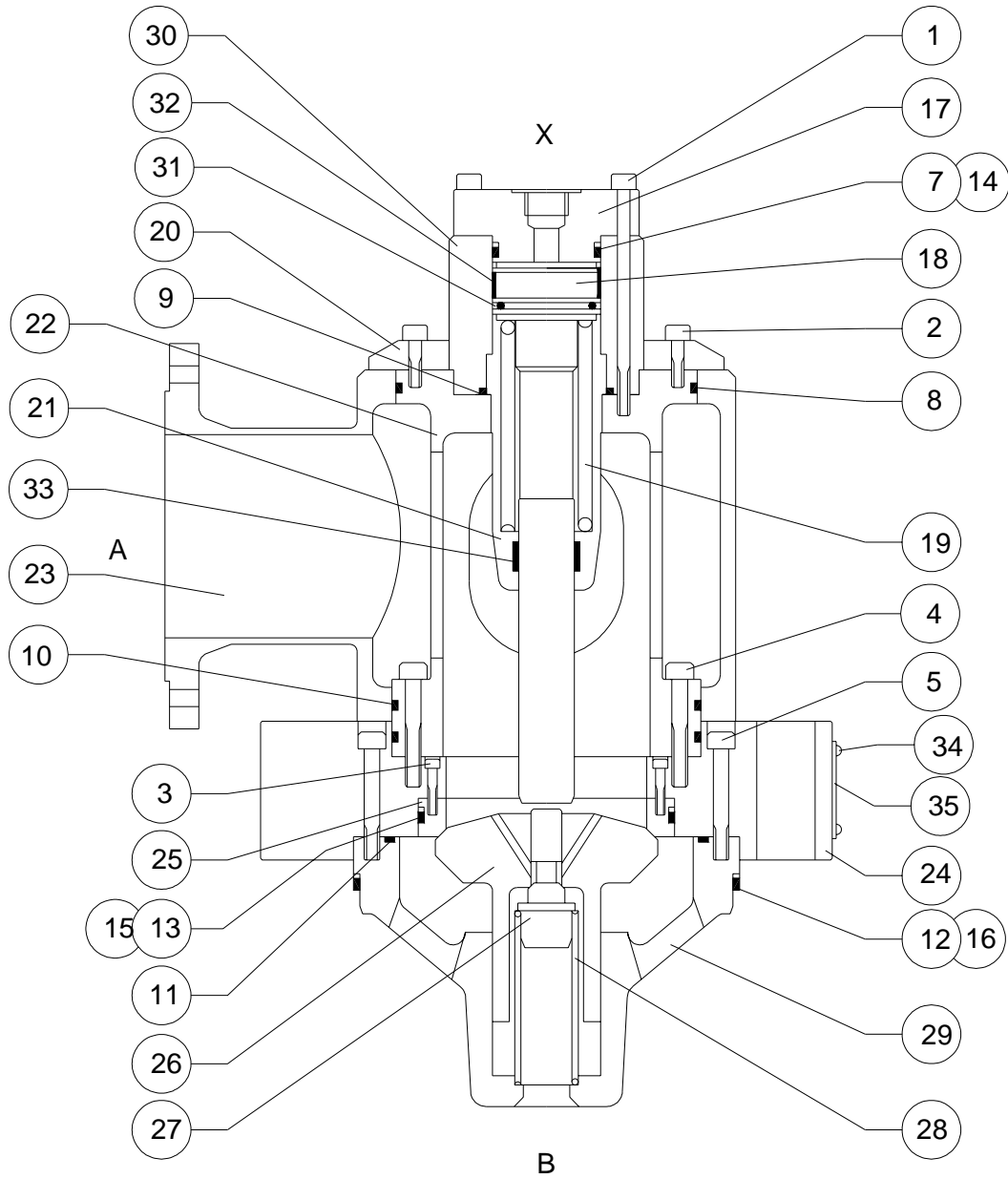

Hydraulic Symbol



# PREFILL AND EXHAUST VALVE PV 100 TO PV 200

**SERVICE**

**6**

Ref. No. P04906

SNo	Description	PV 100			PV 125			PV 150			PV 200		
		Part No.	Size	Qty	Part No.	Size	Qty	Part No.	Size	Qty	Part No.	Size	Qty
1	S.H. Capscrew	55101	M8 x 110L	08	55201	M10 x 140L	08	55301	M12 x 140L	08	55401	M16 x 180L	
2	S.H. Capscrew	55102	M8 x 30L	06	55202	M10 x 35L	06	55302	M12 x 40L	08	55402	M16 x 60L	
3	S.H. Capscrew	55103	M6 x 20L	04	55203	M6 x 30L	04	55303	M6 x 30L	05	55403	M6 x 40L	
4	S.H. Capscrew	55104	M8 x 60L	15	55204	M10 x 65L	15	55304	M12 x 70L	15	55404	M16 x 90L	
5	S.H. Capscrew	55105	M8 x 70L	06	55205	M10x70L	06	55305	M12 x 80L	05	55405	M16 x 90L	
*7	O'ring	55107	Ø50 x 3	01	55207	Ø62 x 4	01	55307	Ø72 x 4	01	55407	Ø103 x 4	
*8	O'ring	55108	Ø148 x 4	01	55208	Ø185x 5	01	55308	Ø220 x 5	01	55408	Ø298 x 7	
*9	O'ring	55109	Ø62 x 3	01	55209	Ø87x 4	01	55309	Ø88 x 4	01	55409	Ø122 x 4	
*10	O'ring	55110	Ø150 x 4	02	55210	Ø190 x 5	02	55310	Ø225 x 5	02	55410	Ø303 x 7	
*11	O'ring	55111	Ø160 x 5	01	55211	Ø200 x 5	01	55311	Ø230 x 5	01	55411	Ø303 x 7	
*12	O'ring	55112	Ø190 x 5	01	55212	Ø240 x 5	01	55312	Ø280 x 5	01	55412	Ø368 x 7	
*13	O'ring	55113	Ø131.5 x 5	01	55213	Ø160 x 5	01	55313	Ø185 x 5	01	55413	Ø250 x 3.5	
*14	Backup Ring	55114	Ø51.4 x Ø56 x 2	01	55214	Ø63.8 x Ø70 x 2	01	55314	Ø73.8 x Ø80 x 2	01	55414	Ø103.8 x Ø11	
*15	Backup Ring	55115	Ø132 x Ø140 x 2	01	55215	Ø162 x Ø170 x 2	01	55315	Ø187 x Ø195 x 2	01	55415	Ø250.6 x Ø25	
*16	Backup Ring	55116	Ø191.6 x Ø200 x 3	01	55216	Ø241.6 x Ø250 x 3	01	55316	Ø281.6 x Ø290 x 3	01	55416	Ø368.6 x Ø38	
17	Cover	55117		01	55217		01	55317		01	55417		
18	Pilot Piston	55118		01	55218		01	55318		01	55418		
#19	Pilot Spring	55119		01	55219		01	55319		01	55419		
20	Clamp	55120		01	55220		01	55320		01	55420		
21	Spring Casing	55121		01	55221		01	55321		01	55421		
22	Casing	55122		01	55222		01	55322		01	55422		
23	Suction Housing	55123		01	55223		01	55323		01	55423		
24	Flange	55124		01	55224		01	55324		01	55424		
25	Valve Seat	55125		01	55225		01	55325		01	55425		
26	Main Poppet	55126		01	55226		01	55326		01	55426		
27	Decomp. Poppet	55127		01	55227		01	55327		01	55427		
#28	Suction Spring	55128		01	55228		01	55328		01	55428		
29	Guide	55129		01	55229		01	55329		01	55429		
30	Housing	55130		01	55230		01	55330		01	55430		
*31	Glyd Ring	55131		01	55231		01	55331		01	55431		
*32	Slyd Ring	55132		01	55232		01	55332		02	55432		
*33	Slyd Ring	55133		01	55233		02	55333		02	55433		
34	Rivet	55134		04	55234		04	55334		04	55434		
35	Label	55135		01	55235		01	55335		01	55435		

**Note :**

\* Recommended spares.

Part no.2,8,10,20 and 22 are not required for 'B' type Pre-fill valves.

While ordering spares give complete description of model no. as punched on the body.