



A Polyhydon Group Company

# RADIAL PISTON DOUBLE PUMPS 2R

ENGINEERING

1

Ref. No. P04894

Release 08/2011

## Description

Radial piston arrangement, with 3, 5 or 7 Pumping elements each per pump section. Fixed delivery, Oil immersed type, Open execution, face mounting, Valve controlled. Bi-directional rotation of shaft.

Flows can be combined internally, externally to feed one circuit or used independently to feed Two circuits.



## Section

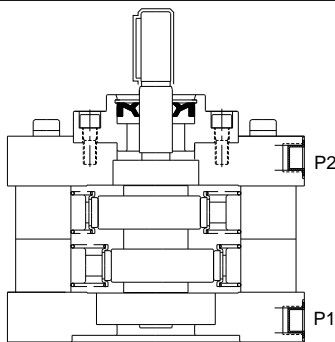

### Hydraulic Symbol

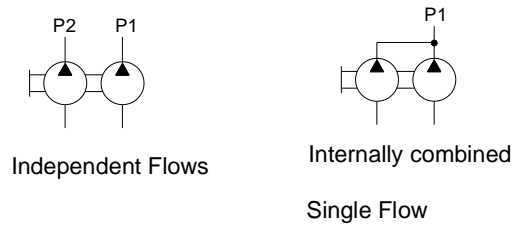

## Unit dimension

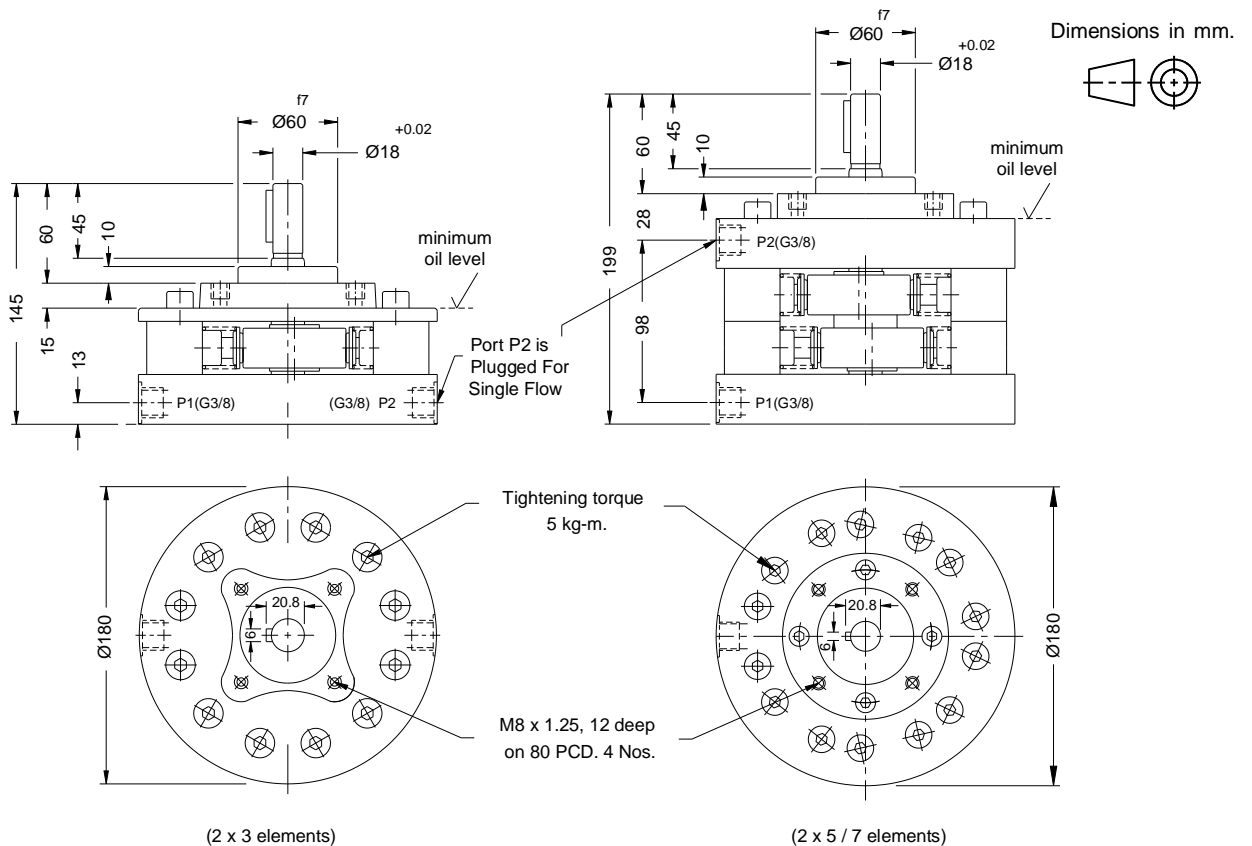

### Polyhydon Pvt. Ltd.

78-80, Machhe Industrial Estate, Machhe  
Belgaum - 590 014. INDIA.

Phone : +91-(0)831-411001  
Fax : +91-(0)831-411002  
E-mail : polyhydon@gmail.com  
Website : www.polyhydon.com



A Polyhydron Group Company

# RADIAL PISTON DOUBLE PUMPS 2R

ENGINEERING

2

Ref. No. P04894

## Technical specification

Designation .....	2R-basic radial piston double pump group.
Design .....	Radial piston, valve controlled.
No. of pistons .....	3,5 or 7 elements each at P1 & P2 port section depending upon flow requirement.
Mounting .....	Face mounting
Interface .....	Factory standard
Direction of rotation .....	2R..... Can be run in either direction
.....2RE .....	Depends upon direction of rotation of pump attached.
Connections .....	Suction .....
.....	Sucks oil directly from tank, no suction port provided
.....	Delivery .....
.....	Port P1 & P2 - G 3/8 female.
Speed range .....	300 to 2000 rpm.
Hydraulic medium .....	Mineral oil
Viscosity range .....	10 to 100 cSt.
Optimum Viscosity range .....	16 to 32 cSt.
Temperature range .....	-10 °C to +80 °C.
	(Do not exceed viscosity limits at extreme temperatures for efficient running of the pump)
Fluid cleanliness requirement .....	As per ISO Code 16/13
Performance .....	Refer Table No. 1
Mass .....	19.8 kg.

Table No. 1

Code No.	Geometrical displacement CC / REV	Rated output at 1450 rpm. (l / min)	Operating pressure bar	Input power requirement (@ 1450 rpm)																					
				50 bar		100 bar		150 bar		200 bar		250 bar		300 bar		350 bar		400 bar		450 bar		500 bar		550 bar	
				KW	Hp	KW	Hp	KW	Hp	KW	Hp	KW	Hp	KW	Hp	KW	Hp	KW	Hp	KW	Hp	KW	Hp	KW	Hp
3A	1.21	1.5	550	0.17	0.23	0.3	0.5	0.7	0.7	0.9	0.9	1.2	1	1.4	1.2	1.6	1.4	1.8	1.6	2.1	1.7	2.3	1.9	2.5	
5A	2.01	2.6	550	0.29	0.38	0.6	0.8	0.9	1.2	1.2	1.5	1.4	1.9	1.7	2.3	2	2.7	2.3	3.1	2.6	3.5	2.9	3.8	3.2	4.2
7A	2.81	3.7	550	0.4	0.54	0.8	1.1	1.2	1.6	1.6	2.2	2	2.7	2.4	3.2	2.8	3.8	3.2	4.3	3.6	4.8	4	5.4	4.4	5.9
3B	1.88	2.5	450	0.27	0.36	0.5	0.7	0.8	1.1	1.1	1.4	1.3	1.8	1.6	2.2	1.9	2.5	2.1	2.9	2.4	3.2				
5B	3.14	4.2	450	0.45	0.6	0.9	1.2	1.3	1.8	1.8	2.4	2.2	3	2.7	3.6	3.1	4.2	3.6	4.8	4	5.4				
7B	4.4	5.8	450	0.63	0.84	1.3	1.7	1.9	2.5	2.5	3.4	3.1	4.2	3.8	5	4.4	5.9	5	6.7	5.6	7.5				
3C	2.71	3.7	350	0.39	0.52	0.8	1	1.2	1.6	1.5	2.1	1.9	2.6	2.3	3.1	2.7	3.6								
5C	4.52	6.2	350	0.64	0.86	1.3	1.7	1.9	2.6	2.6	3.5	3.2	4.3	3.9	5.2	4.5	6								
7C	6.33	8.6	350	0.9	1.21	1.8	2.4	2.7	3.6	3.6	4.8	4.5	6	5.4	7.2	6.3	8.5								
3D	3.19	4.3	300	0.45	0.61	0.9	1.2	1.4	1.8	1.8	2.4	2.3	3	2.7	3.6										
5D	5.31	7.2	300	0.76	1.01	1.5	2	2.3	3	3	4.1	3.8	5.1	4.5	6.1										
7D	7.43	10	300	1.06	1.42	2.1	2.8	3.2	4.3	4.2	5.7	5.3	7.1	6.3	8.5										
3E	3.69	5	250	0.53	0.7	1	1.4	1.6	2.1	2.1	2.8	2.6	3.5												
5E	6.16	8.4	250	0.88	1.17	1.8	2.4	2.6	3.5	3.5	4.7	4.4	5.9												
7E	8.62	11.7	250	1.23	1.64	2.5	3.3	3.7	4.9	4.9	6.6	6.1	8.2												
3F	4.24	5.8	200	0.6	0.81	1.2	1.6	1.8	2.4	2.4	3.2														
5F	7.07	9.7	200	1	1.35	2	2.7	3	4	4	5.4														
7F	9.9	13.6	200	1.11	1.89	2.8	3.8	4.2	5.7	5.6	7.5														

**Note :** For double pumps, the above pump code number needs to be modified in the following manner. The first digit in the code number indicates number of pumping elements in each pump section. The second letter indicates flow and pressure rating of the pumping elements of P1 port end section and the third letter indicates flow and pressure rating of the pump elements of P2 port end section. Code no. 5AD for example, indicates a double pump having a flow and pressure rating of 5A for P1 port end section and 5D rating for P2 port end section.

**Torque Limitation :** The sum of torque used for P1 and P2 port end section should not exceed 70 Nm (11 kw at 1450 rpm) at any given instance.



A Polyhydron Group Company

# RADIAL PISTON DOUBLE PUMPS 2R

ENGINEERING

3

Ref. No. P04894

## Accessories

**Extension shaft** (For through drive)  
Dimensions

Note :  
Torque limitation - The sum of torque used for the piston pump and torque used at extended shaft end should not exceed 75 Nm ( 11kW @ 1450 rpm )

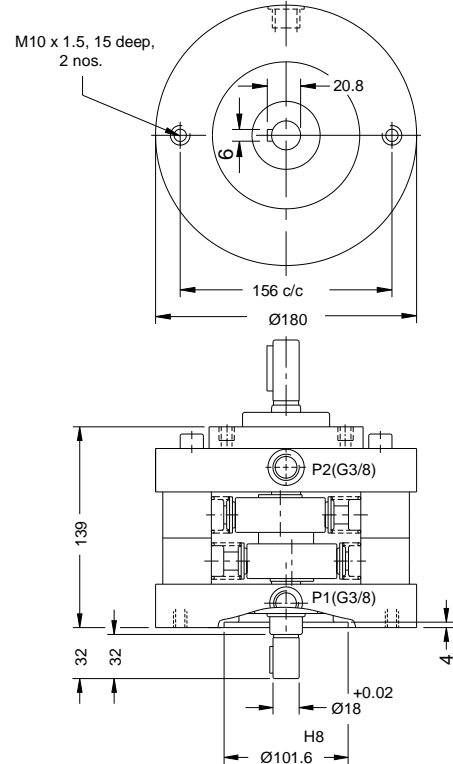

## Ordering code

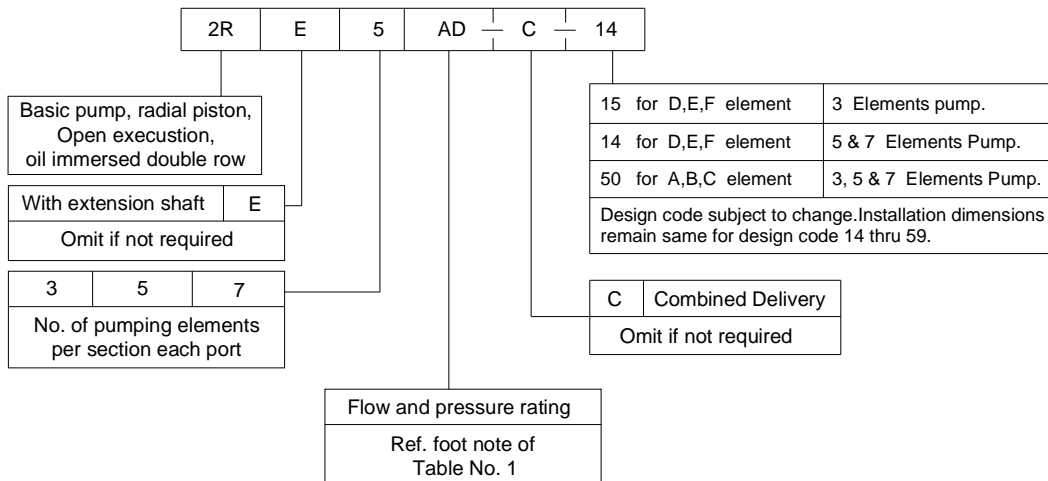

Note 1 : A double pump of model code 2R5AD-14, for example, will have 5 pumping elements of 'A' flow and pressure rating at its P1 port end section and 5 pumping elements of 'D' flow and pressure rating at its P2 port end section.

Note 2 : An Internally combined single flow pump of model code 2R5AD-C-14, for example, will have 5 pumping elements of 'A' flow and pressure rating at its P1 port end section and 5 pumping elements of 'D' flow and pressure rating at its P2 port end section.

The maximum pressure available will be, minimum of above combination of pumping elements.

Note 3 : For Bell housing assembly Refer Sheet No. P09035.  
For Extension Bracket refer Sheet No. P09090.



A Polyhydron Group Company

# RADIAL PISTON DOUBLE PUMPS 2R

SERVICE

4

Ref. No. P04894

## Sectional view and Part list of 2R3\*\* / 2RE3\*\* and 2R3\*\*-C / 2RE3\*\*-C

Hydraulic Symbol

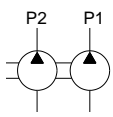

dependent Flows

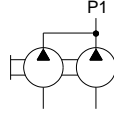

Internally combined

Single Flow

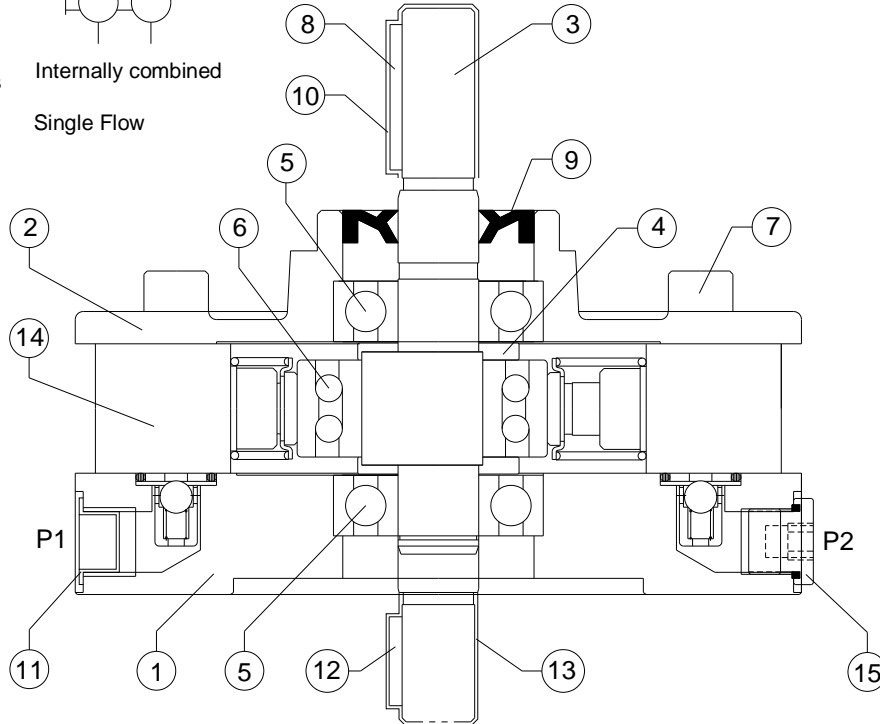

	SI.No.	Description	2R3**		2RE3**		Product	Size	Qty.
			2R3**-C		2RE3**-C				
For 2R3**-C and 2RE3**-C	1	Valve plate	11206						1
	2	Cover plate	11226						1
	3	Shaft	11242	11243					1
	4	Balancing Plate	11251						2
	5	Bottom Bearing	11261				6304		2
	6	Centre Bearing.	11262				3206		1
	7	Cap screw	11271				M10 x 55 L		12
	8	Shaft Key	11293				6 x 6 x 36		1
	* 9	Rotary Shaft Seal	11277				Dou. Lip 47		1
	10	Plastic cap	11283				1R ( Shaft )		1
	11	Rubber Port Plug	00012				G 3/8 Plug Cap		2
	12	Shaft Key	--	11294			6 x 6 x 22		1
	13	Plastic cap	--	11284			1RE ( Shaft )		1
	14	Pump element assly. (Refer Data Sheet No. D 11100)					1R-A-01 / 1R-B-01 1R-C-01 / 1R-D-01 1R-E-01 / 1R-F-01		6
	15	Elastomeric plug	00203				G3/8		1

Note : Specified part numbers are available as spares.

\* Recommended seal kit.



A Polyhydron Group Company

# RADIAL PISTON DOUBLE PUMPS 2R

SERVICE

Ref. No. P04894

## Sectional view and Part list of 2R(5/7)\*\* / 2RE(5/7)\*\* and 2R(5/7)\*\*-C / 2RE(5/7)\*\*-C

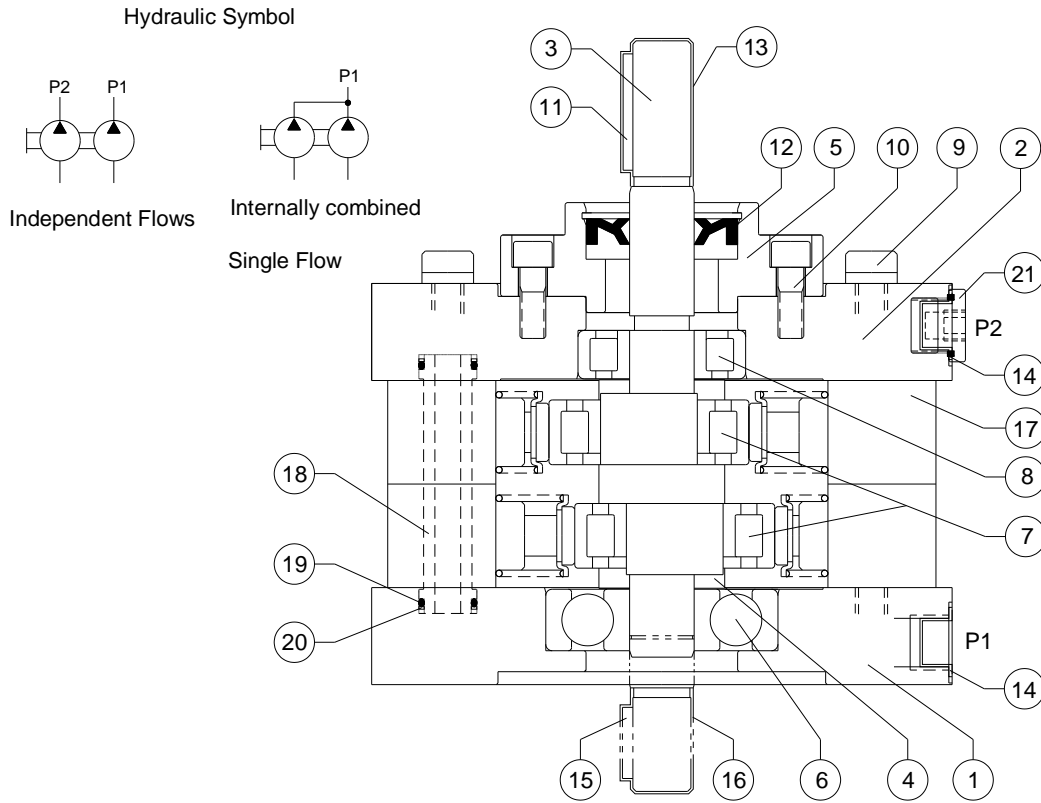

		2R5** / 2R7**	2RE5** / 2RE7**				
		2R5**-C / 2R7**-C	2RE5**-C / 2RE7**-C	Product	Size	Qty.	
For 2R(5/7)**-C and 2RE(5/7)**-C For 2R(5/7)** and 2RE(5/7)**	Sl.No.	Description	Part No.	Part No.			
	1	Valve plate	11208 / 11211	11208 / 11211		1	
	2	Valve plate	11210 / 11213	11210 / 11213		1	
	3	Shaft	11244	11245		1	
	4	Balancing Plate		11253		2	
	5	Mounting Flange		11236		1	
	6	Bottom Bearing		11264		6404	1
	7	Centre Bearing.		11265		NUP 2206	2
	8	Top Bearing.		11266		NJ 304 ECP	1
	9	Cap screw		11272		M10 x 110 L	10/14
	10	Cap screw		00116		M8 x 20 L	4
	11	Shaft Key		11293		6 x 6 x 36	1
	* 12	Rotary Shaft Seal		11277		Dou. Lip 47	1
	13	Plastic cap		11283		1R ( Shaft )	1
	14	Rubber Port Plug		00012		G 3/8 Plug Cap	2
	15	Shaft Key	--	11294		6 x 6 x 22	1
	16	Plastic cap	--	11284		1RE ( Shaft )	1
	17	Pump element assly. (Refer Data Sheet No. D 11100)			1R-A-01 / 1R-B-01 1R-C-01 / 1R-D-01 1R-E-01 / 1R-F-01		10/14
	18	Connecting Pipe		11259			1
	19	O'ring		11295		14 x 2	2
	20	Back up ring		11296		14.6 x 18 x 1.2	2
21	Elastomeric plug		00203		G 3/8	1	

All rights reserved.  
Subject to revision.

Note : Specified part numbers are available as spares.

\* Recommended seal kit.