



# PILOT OPERATED PRESSURE RELIEF CUM UNLOADING VALVES PPRU

**ENGINEERING**

**1**

**Ref. No. P03600**

Release 02/2009

## Description

Two stage poppet type Relief cum unloading valve.  
Additional solenoid unloading facility as an optional feature.  
Three standard sizes - 10, 20, & 30.



## Section

### Hydraulic Symbol

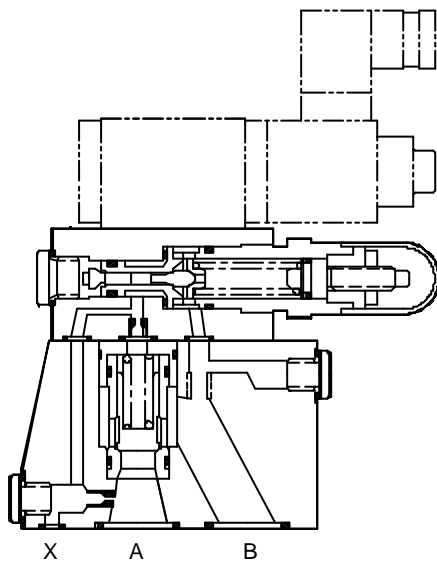

PPRU	Normally	
Description	Open	Close
Internal pilot Internal Drain P - Unloading pressure		
X - External pilot Internal Drain P - Unloading pressure		
Internal pilot Y-External Drain P - Unloading pressure		
X - External pilot Y - External Drain P - Unloading pressure		

**Polyhydron Pvt. Ltd.**  
78-80, Machhe Industrial Estate,  
Machhe, Belgaum - 590 014. INDIA.

**Phone** : +91-(0)831-2411001  
**Fax** : +91-(0)831-2411002  
**E-mail** : polyhydron@gmail.com  
**Website** : www.polyhydron.com



# PILOT OPERATED PRESSURE RELIEF CUM UNLOADING VALVES PPRU

ENGINEERING

2

Ref. No. P03600

## Unit Dimensions

### Subplate Type

Size	10	20	30
Mass Kg.	4.8	6.7	12
H1	125	126	145
H2	95	75	75
H3	13	12	14
L1	84	100	128
L2	31	28.9	31.8
L3	--	--	42.1
L4	42.9	60.3	84.1
W1	88	100	120
W2	66.7	79.4	96.8

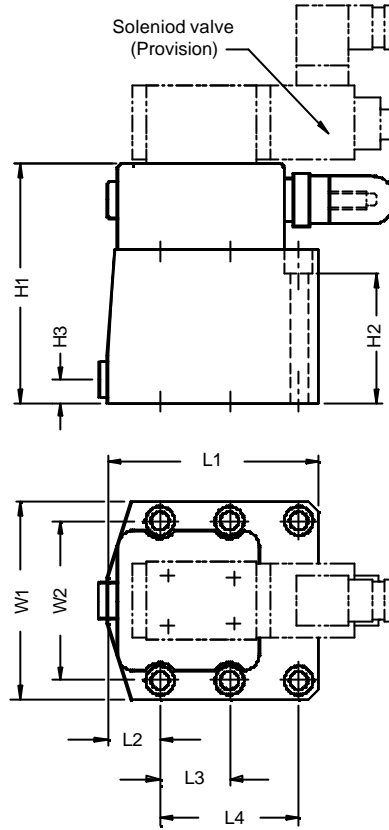

### Threaded Type

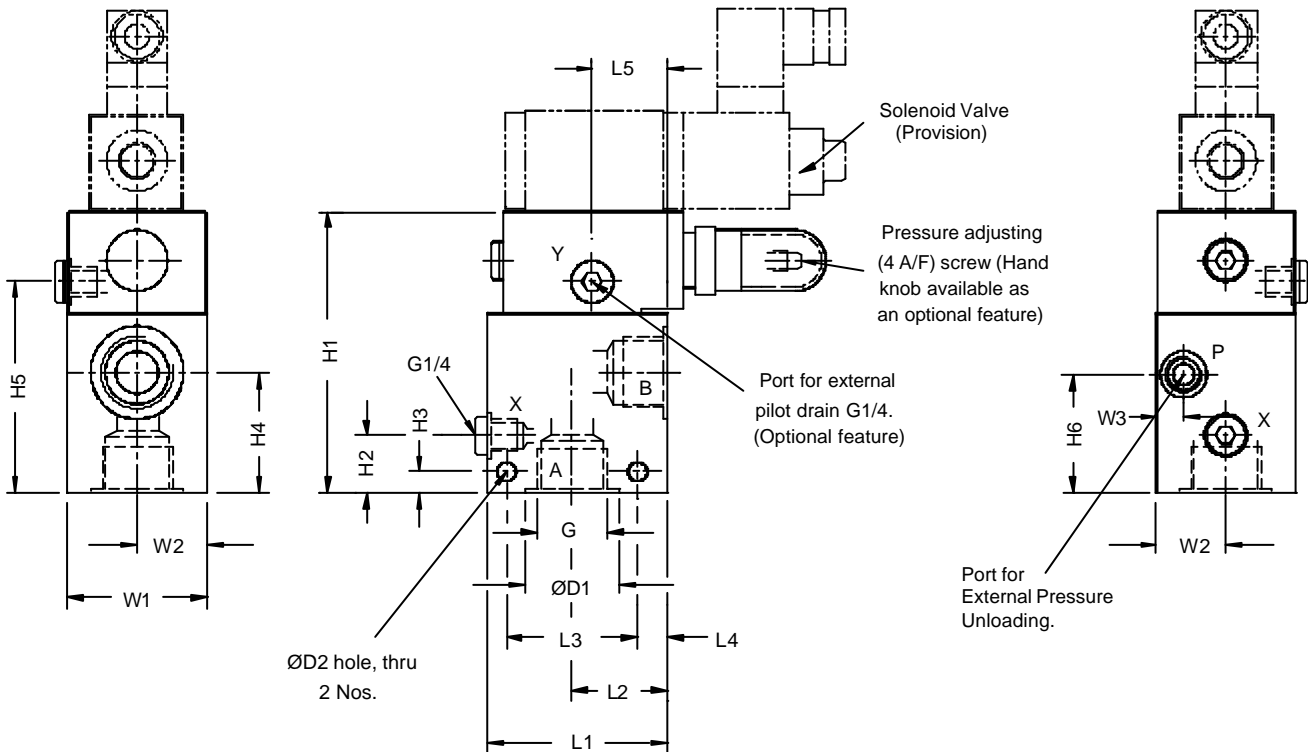

Size	Mass Kg.	G	H1	H2	H3	H4	H5	H6	L1	L2	L3	L4	L5	W1	W2	W3	ØD1	ØD2
20	4.8	G1	138	27	10	57	100	50	85	45	62	14	35.5	66	33	12	44	9
30	9.5	G1 1/2	175	42	13	80	138	80	100	54	72	18	41.5	86	43	14	60	11



# PILOT OPERATED PRESSURE RELIEF CUM UNLOADING VALVES PPRU

ENGINEERING

3

Ref. No. P03600

### Subplate ( Not in supply )

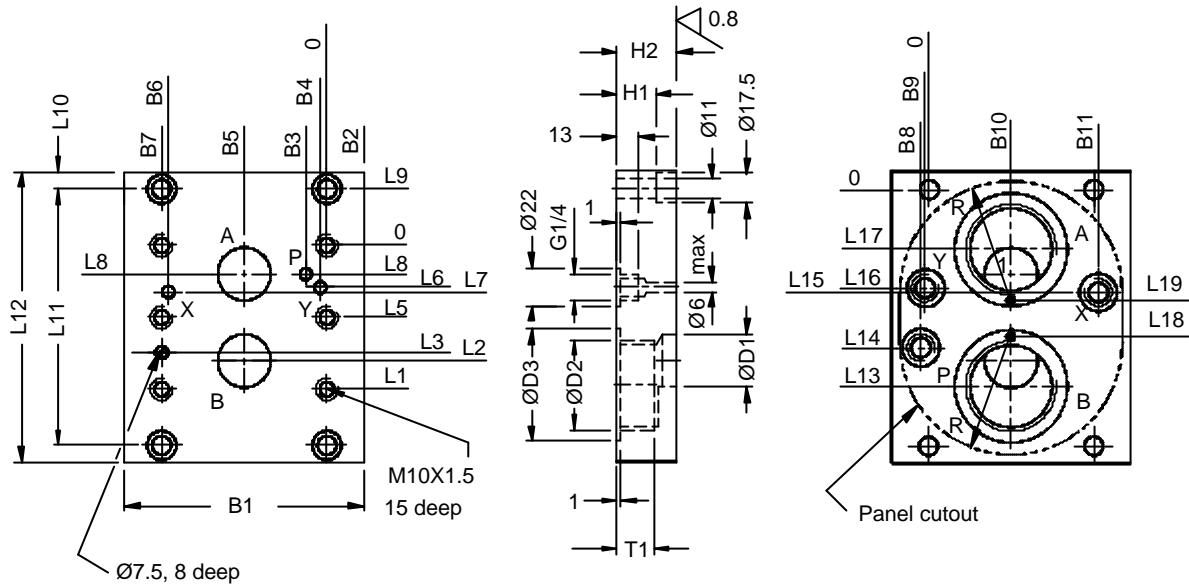

Size	Model No.	Mass kg	B1	B2	B3	B4	B5	B6	B7	B8	B9	B10	B11	ØD1	ØD2	ØD3
10	1SU06G02	2.4	86	9.6	11	7.9	33.3	58.7	66.7	-33.3	-7.9	33.3	58.7	13	G1/4	22
	1SU06G03														G3/8	25
	1SU06G04														G1/2	30
20	1SU08G06	5.2	112	16.3	14	6.4	39.7	73	79.4	3	3	39.7	75	22	G3/4	36
	1SU08G08														G1	44
30	1SU09G10	8.5	140	21.6	15	4	48.4	92.9	96.8	1.6	1.6	48.4	98.5	31	G1¼	54
	1SU09G12														G1½	60

Size	Model No.	H1	H2	L1	L2	L3	--	L5	L6	L7	L8	L9	L10	L11	L12	L13
10	1SU06G02	15	29	42.9	35.7	31.8	--	--	21.4	21.4	7.1	45.9	10	121	141	85
	1SU06G03															
	1SU06G04															
20	1SU08G06	25	45	60.5	49.2	44.5	--	--	39.7	20.8	11.1	22	16	104	136	77
	1SU08G08															
30	1SU09G10	35	47	84.1	67.5	62.7	--	42.1	59.6	24.6	16.7	33	10	150	170	111
	1SU09G12															

Size	Model No.	L14	L15	L16	L17	L18	L19	R	T1	Valve fixing screws	Tightening torque
10	1SU06G02	11	67.3	67.3	49	82	53	40	12	SHCS. M10 x 110 L, 4 Nos	70 Nm
	1SU06G03										
	1SU06G04										
20	1SU08G06	39	42.6	64	27	57	47	52	16	SHCS. M10 x 90 L, 4 Nos.	
	1SU08G08										
30	1SU09G10	50	60	99.1	39	90	60	65	20	SHCS. M10 x 90 L, 6 Nos.	
	1SU09G12										



# PILOT OPERATED PRESSURE RELIEF CUM UNLOADING VALVES PPRU

**ENGINEERING**

**4**

**Ref. No. P03600**

## Technical Specifications

Construction .....	Two stage poppet valve.
Mounting .....	Sub-Plate Mounting conforming to ISO 5781 with additional pilot pressure port 'P'
Mounting position .....	Optional
Flow direction .....	From port 'A' to 'B'
Operating pressure .....	For port 'A' , 'X' and 'P' ..... 315 bar For port 'B' ..... 60 bar
Hydraulic medium .....	Mineral oil
Viscosity range .....	10 Cst to 380 Cst.
Fluid temperature range .....	-20 ° to +70 °C.
Fluid cleanliness requirement .....	As per ISO 16/13
Maximum flow handling capacity .....	For valve size 10 ..... 100 Ltrs./min. 20 ..... 200 Ltrs./min. 30 ..... 400 Ltrs./min.
Mass .....	Refer individual Table

## Ordering Code

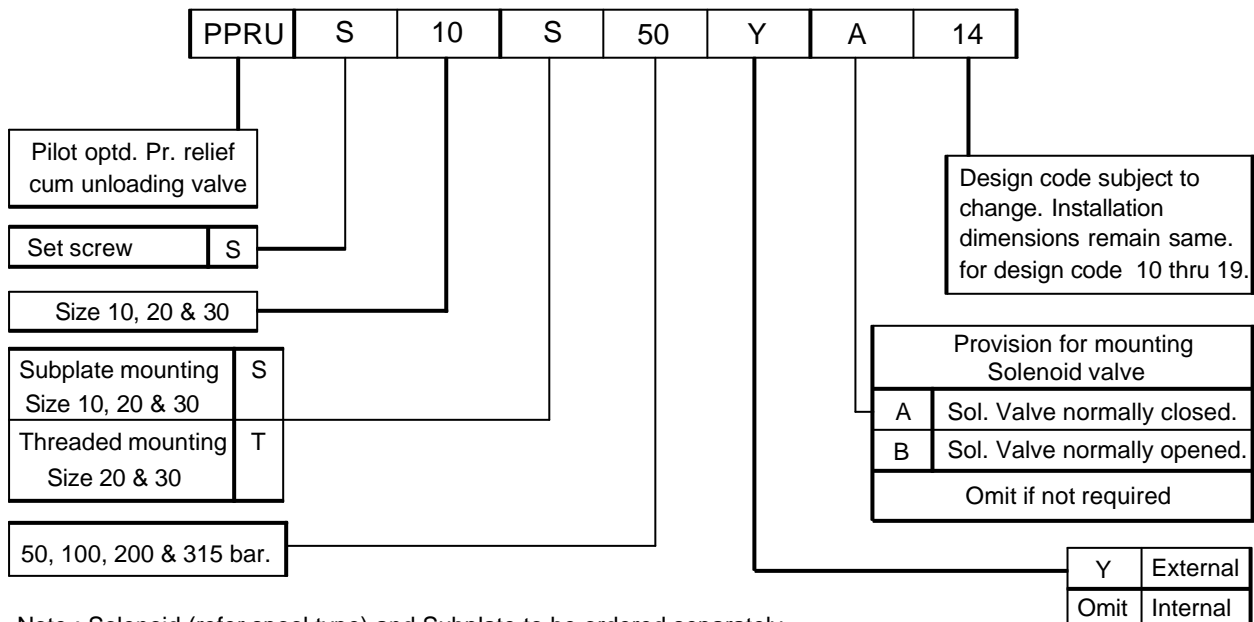

Note : Solenoid (refer spool type) and Subplate to be ordered separately.

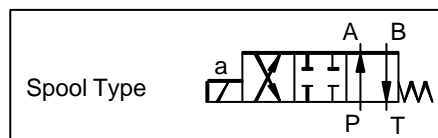

All rights reserved.  
Subject to revision.