



PRESSURE COMPENSATED FLOW CONTROL VALVE 2PF

ENGINEERING

2

Ref. No. P05083

Subplate dimensional information is only for reference.

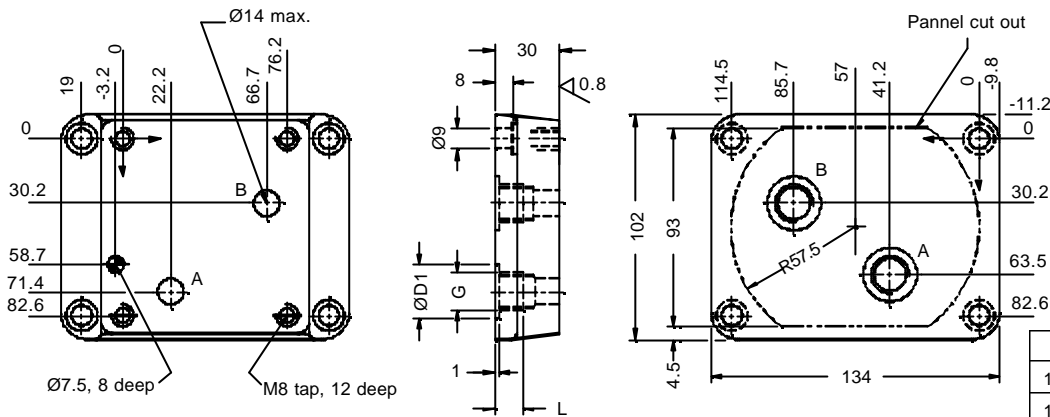

Technical specification

Construction Differential piston with sharp edge orifice.
 Mounting Threaded and Subplate mounting.
 Mounting position Optional.
 Interface CETOP 06, ANSI 2 F02 ISO 6263-06-05.
 Flow direction Controlled flow from Port A to B with optional reverse-free check valve.
 Operating pressure 315 bar.
 Minimum Pressure differential Between Port A & B 7 bar.
 Hydraulic medium Mineral oil.
 Viscosity range 10 cSt to 380 cSt.
 Working temperature range -20 °C to +70 °C.
 Fluid cleanliness requirement As per ISO 16/13 or better.
 Flow controlling capacity Minimum 0.25 to 4, 8, 16 or 32 lpm.
 Flow Controlling Accuracy ±2%
 Mass 4.2 kg APPROX.

Ordering code

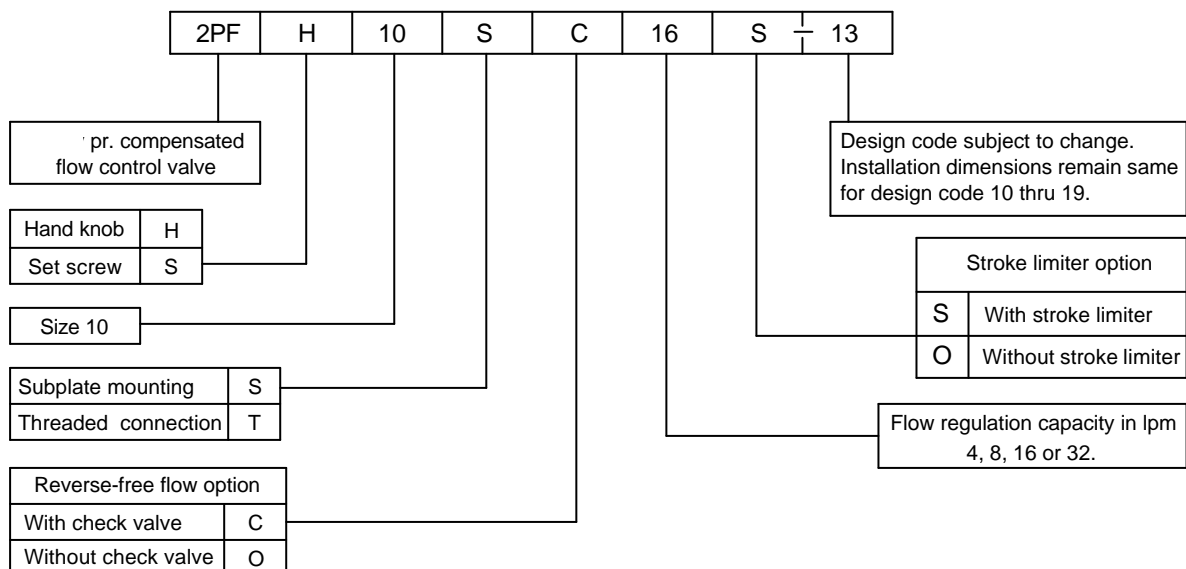

Note : Subplate to be ordered separately

Sectional View and Spare part details

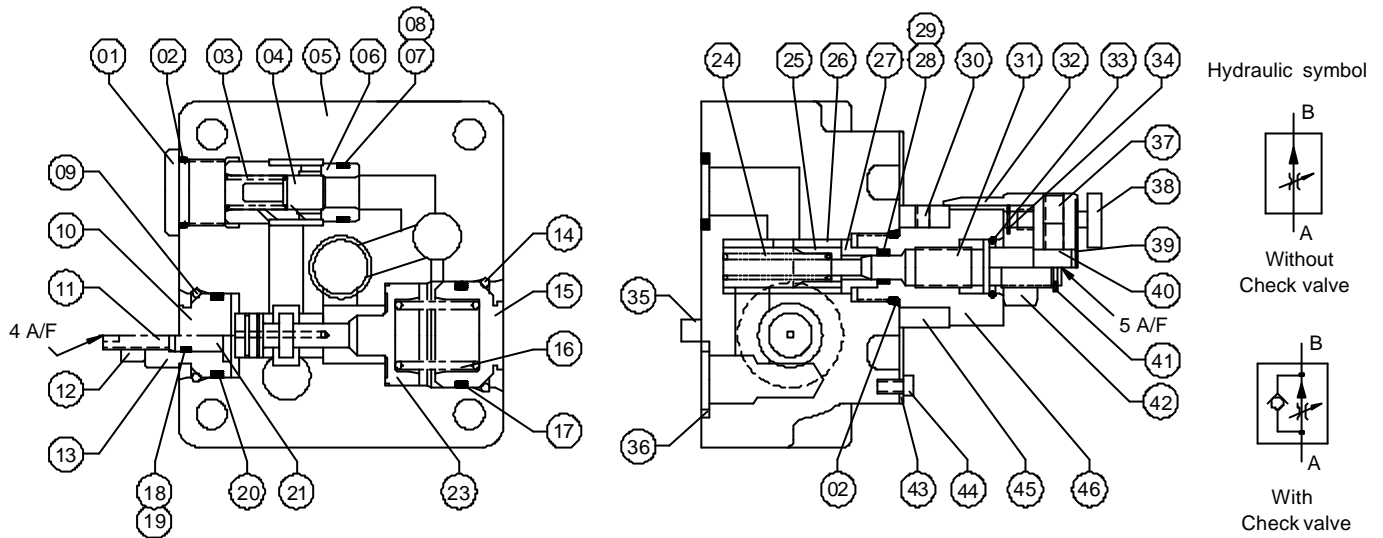

Sl.no.	Description	Qty.
1	Plug	1
* 2	O' Ring (Viton)	2
3	Spring	1
4	Poppet	1
5	Body	1
6	Check Valve Bush	1
7	O' Ring	1
8	Backup Ring	2
9	Spring Ring Sl. No.17	1
10	End Cover	1
11	Socket Set Screw	1
12	Check Nut	1
13	Stroke limiter cover	1
14	Spring Ring Sl. No 5	1
15	Rear end cover	1
16	Spring	1
* 17	O' Ring (Viton)	1
* 18	O' Ring (Viton)	1
19	Backup Ring	1
* 20	O' Ring (Viton)	1
21	Stroke Adjuster	1
--	--	--
23	Spool	1

Sl.no.	Description	Qty.
24	Spring	1
25	Piston	1
26	Orifice Body	1
27	Bush	1
28	O' Ring (Viton)	1
* 29	Backup Ring	1
30	Socket Set Screw	1
31	Spindle	1
32	Knob	1
33	Spring Ring Sl. No.15	1
34	Circlip External	1
35	Spring Dowel	1
* 36	O' Ring (Viton)(For Subplate Model only)	2
37	Socket Set Screw	1
38	Lock Screw	1
39	Label	1
40	Spindle	1
41	Circlip External	1
42	Check Nut	1
43	Label Plate	1
44	Cheese Head Screw	4
45	Graduation Ring	1
46	Gland	1

Note : * Recommended seal kit. * & □ Recommended spare kit.
While ordering the individual spares / seal kit / spare kit give part.no.
and complete details of model code as punched on the pump body.