



FOOT PUMP FP

ENGINEERING

1

Ref. No. P06565

Release 08/99

Description

Heavy duty construction with hardened and ground plunger. Both suction and delivery valve seats are replaceable. Intended for supply of lubricating oil or pilot pressure.



Section

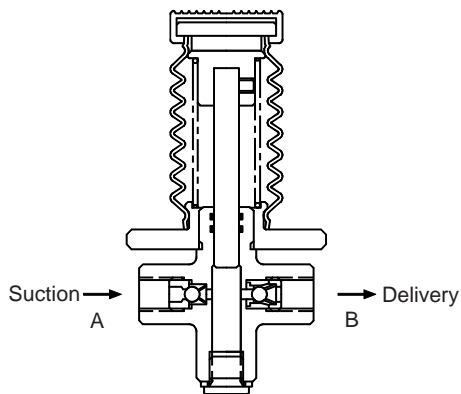

Hydraulic Symbol



Unit dimension

Dimensions in mm.

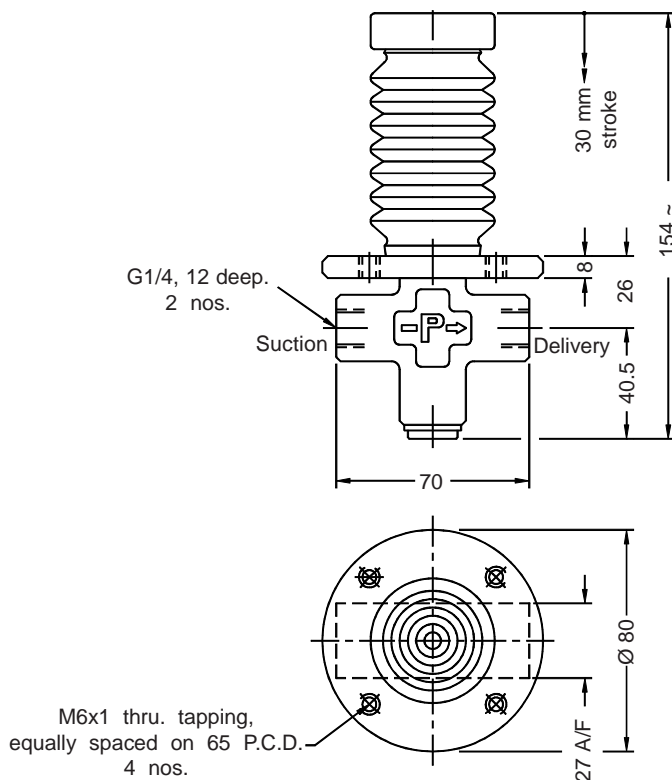
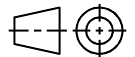

Polyhydron Pvt. Ltd.

78-80, Machhe Industrial Estate, Machhe,
Belgaum - 590 014, INDIA.

Phone : +91-(0)831-411001

Fax : +91-(0)831-411002

E-mail : polyhydron@vsnl.com

Website : www.polyhydron.com



FOOT PUMP
FP

ENGINEERING

2

Ref. No. P06565

Technical specification

Construction	Plunger type.
Direction of flow	As per hydraulic symbol.
Flow handling capacity	2.35 cc/stroke.
Operating pressure	35 bar.
Operating force at 25 bar	300 N.
Max. suction pressure	100 mm of Hg.
Viscosity range	10 cSt to 380 cSt.
Fluid temperature range	-10 °C to +80 °C.
Fluid cleanliness requirement	As per ISO 16/13.
Mass	0.9 Kg.

Ordering code

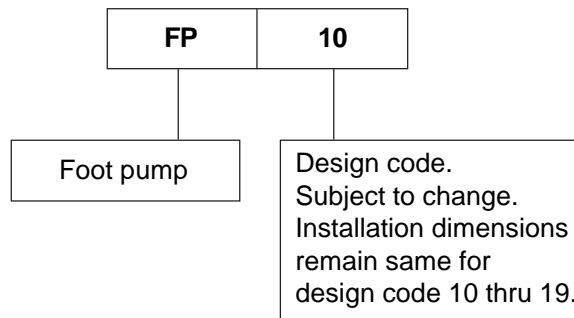

All rights reserved.
Subject to revision.